

Max, 30mm Blade Length!

- 30mm blade length and originally designed breaker ensured maximum 30mm Chamfering process without chattering
- Line-up 5°~85° Angle process are ensured

Maximum blade length
About 30mm

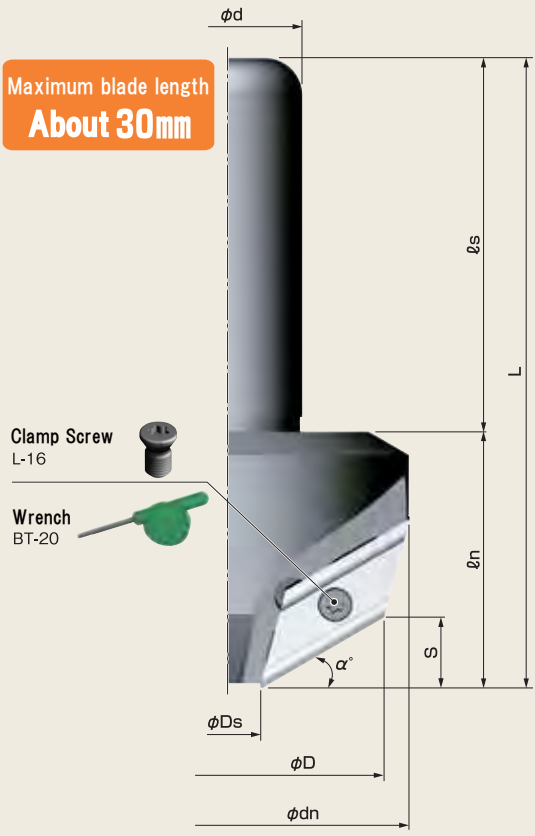

Corner Chamfering



Body

Model. No.	Blades	Dimensions (mm)								α°
		φD	φDs	φd	φdn	L	ℓs	ℓn	S	
NK4554X-1	1	54.9	12.0	32		135	80	55	21.4	45
NK0574X	3	74.8	15.0	32	102.8	135	80	55	2.6	5
NK1074X	3	74.5	15.0	32	99.5	135	80	55	5.2	10
NK1571X	3	73.3	15.0	32	95.2	135	80	55	7.8	15
NK2070X	3	71.8	15.0	32	90.3	135	80	55	10.3	20
NK2568X	3	69.8	15.0	32	84.9	135	80	55	12.8	25
NK3080X	3	67.4	15.0	32	79.0	135	80	55	15.1	30
NK3563X	3	64.6	15.0	32	72.8	135	80	55	17.4	35
NK4060X	3	61.4	15.0	32	66.3	135	80	55	19.5	40
NK4557X	3	57.9	15.0	32		135	80	55	21.4	45
NK5056X	3	57.0	18.0	32		135	80	55	23.2	50
NK5556X	3	56.8	22.0	32		135	80	55	24.8	55
NK6054X	3	54.3	24.0	32		135	80	55	26.3	60
NK6553X	3	53.6	28.0	32		145	80	65	27.5	65
NK7052X	3	52.8	32.0	32		145	80	65	28.5	70
NK7550X	3	50.7	35.0	32		145	80	65	29.3	75
NK8048X	3	48.5	38.0	32		145	80	65	29.9	80
NK8547X	3	47.3	42.0	32		145	80	65	30.3	85

※ Inset is not equipped as standard accessory

※ Clamp screw and wrench are supplied as standard accessory

Processing Example

[C20 Chamfering]

- Body : NK4557X
- Insert : X63GUR AC15N
- Material : SUS304
- Rotation Speed : 800r.p.m
- Table feed : 150mm/min
- Cutting Depth : C20
- Cutting Oil : None



Dry cutting

Result

Good!
By one pass process, C20 Chamfer has been successfully made without chattering

Cutting Conditions

X63GUR				
Material	material Model	NK1010	NK2020	AC15N
General Steel	0.05~0.15		1,000~2,000	1,000~2,000
Alloy Steel	0.05~0.15		1,000~2,000	1,000~2,000
Stainless Steel	0.05~0.15		700~1,500	700~1,500
Aluminum, Resin, Brass	0.08~0.2	3,000~5,000		
Cast Steel	0.05~0.15	1,000~2,000		

- According to the shape of work, clamp condition and large or small chamfering amount, the cutting condition will have to be adjusted.
- Yellow marked condition is recommended for the material listed
- In case of chamfering process of Stainless steel, kindly take down cutting

Insert

Figure	Model.No.	Material	Blade Shape	Coating	Usable corner	Quantity per box
	X63GUR NK1010	Carbide K10	Sharp edge	None	2	3
	X63GUR NK2020	Carbide M20	Honing edge	None	2	3
	X63GUR AC15N	Fine particles Carbide	Honing edge	AlCrN	2	3